

HITACHI

MODEL
RA-08QDF
RA-10QDF
RA-13QDF

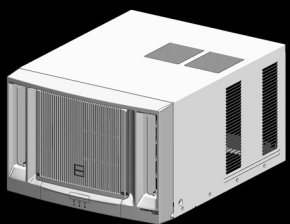

WINDOW TYPE ROOM AIR CONDITIONER OPERATION AND INSTALLATION MANUAL

SAFETY PRECAUTION

- Read the safety precautions carefully before operating the unit.
- The contents of this section are vital to ensure safety. Please pay special attention to the following sign.
 - WARNING** Incorrect methods of installation may cause death or serious injury.
 - CAUTION** Improper installation may result in serious consequence.
 - The sign in the figure indicates prohibition.

Be sure that the unit operates in proper condition after installation. Explain to customer the proper way of operating the unit as described in the user's manual.

PRECAUTIONS DURING INSTALLATION

- | | |
|----------------|---|
| WARNING | <ul style="list-style-type: none"> Please ask sales agent or qualified technician for the installation of the unit. Water leakage, short circuit or fire may occur if install the unit improperly. |
| CAUTION | <ul style="list-style-type: none"> Please use earth line. Do not place the earth line near water or gas pipes, lightning-conductor, or the earth line of telephone. Improper installation of earth line may cause electric shock. A circuit breaker should be installed depending on the mounting site of the unit. Without a circuit breaker, the danger of electric shock exists. Do not install near location where there is flammable gas. The unit may catch fire if flammable gas leaks around it. If drain pan is used, please ensure that when installing the drain hose, water is able to flow freely without any obstruction. |

PRECAUTIONS DURING SHIFTING OR MAINTENANCE

- | | |
|----------------|--|
| WARNING | <ul style="list-style-type: none"> If abnormal situation arises (like burning smell), please stop the unit and turn off the circuit breaker. Fault, short circuit or fire may occur if the unit is continue to operate under abnormal situation. Please contact your agent for maintenance. Improper maintenance may cause electric shock and fire. Please contact your agent if need to remove and reinstall the unit. Electric shock or fire may occur if you remove and reinstall the unit improperly. |
|----------------|--|

PRECAUTIONS DURING OPERATION

- | | |
|--|--|
| WARNING | <ul style="list-style-type: none"> Avoid an extended period of direct air flow from the unit for your health. |
| | <ul style="list-style-type: none"> Do not put objects like thin rods into the unit because the high-speed fan inside may cause danger. |
| | <ul style="list-style-type: none"> Do not use any conductor as fuse wire, this could cause fatal accident. |
| | <ul style="list-style-type: none"> During thunder storm, disconnect the power supply and turn off the circuit breaker. |
| | <ul style="list-style-type: none"> The product shall be operated under the manufacturer specification and not for any other intended use. |
| | <ul style="list-style-type: none"> Do not attempt to operate the unit with wet hands, this could cause fatal accident. |
| | <ul style="list-style-type: none"> When operating the unit with burning apparatus, regularly ventilate the room to avoid oxygen insufficiency. |
| | <ul style="list-style-type: none"> Do not direct the cool air from the air-conditioner towards any household heating apparatus as this may affect the operation of apparatus such as the electric kettle, oven etc. |
| | <ul style="list-style-type: none"> Please ensure that mounting frame is always stable, firm and without defect. Otherwise, the unit may collapse and cause danger. |
| | <ul style="list-style-type: none"> Do not splash or direct water to the body of the unit when cleaning it as this may cause short circuit. |
| | <ul style="list-style-type: none"> Do not place plants directly under the air flow as it is bad for the plants. |
| | <ul style="list-style-type: none"> Please switch off the unit and turn off the circuit breaker during cleaning, the high-speed fan inside the unit may cause danger. |
| | <ul style="list-style-type: none"> Turn off the circuit breaker if the unit is not be operated for a long period. |
| | <ul style="list-style-type: none"> Do not climb on the unit or put objects on it. |
| | <ul style="list-style-type: none"> Do not put water container (like vase) on the unit to avoid water dripping into the unit. Dripping water will damage the insulator inside the unit and causes short circuit. |
| <ul style="list-style-type: none"> When operating the unit with the door and windows opened, and/or with the air deflector facing down for a long period of time, water will condensed on the air deflector and drips down occasionally. This will wet your furniture. Therefore, do not operate under such condition for a long time. If the amount of heat in the room is above the cooling capability of the unit (for example: more people entering the room, using heating equipments and etc.), the preset room temperature cannot be achieved. This appliance can be used by children aged from 8 years and above and persons with reduced physical, sensory or mental capabilities or lack of experience and knowledge if they have been given supervision or instruction concerning use of the appliance in a safe way and understand the hazards involved. Children shall not play with the appliance. Cleaning and user maintenance shall not be made by children without supervision. | |

PARTS IDENTIFICATION AND OPERATIONS

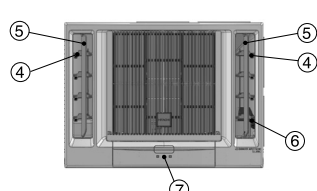
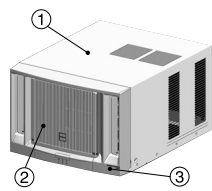

- Cabinet
- Suction Grille
- Front Cover
- Horizontal Deflectors
- Vertical Deflector
- Air Exhaust Lever
- Switch Panel Cover

Model	Width	Height	Depth
RA-08QDF RA-10QDF	18 1/2", 470mm	13 1/2", 345mm	25 3/16", 640mm
RA-13QDF	22 3/64", 560mm	14 3/4", 375mm	27 29/32", 709mm

CONTROL PANEL

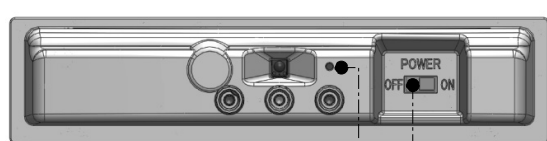

INDICATION LAMP

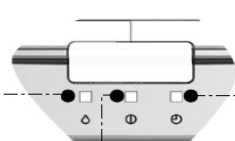

TEMPORARY SWITCH
Use this switch to start operation and stop when the remote controller does not work. Normally do not use this switch

POWER SWITCH

DEHUMIDIFY LAMP

TIMER LAMP

TEMPORARY SWITCH

Use the temporary switch for start or stop operation when operation cannot be done with the remote controller. By pressing the temporary switch, [use non-conductor stick (for example: toothpick),] the operation will follow previous operation mode. When the operation is done using the temporary switch, after the power source is turned off and is turned on again, the operation is done in automatic mode.

<1A0000: A>

AIR DEFLECTORS

VERTICAL DEFLECTORS

Vertical deflectors at both sides of outlets can be set to either auto-swing or static position to direct discharge air rightward, leftward or forward direction.

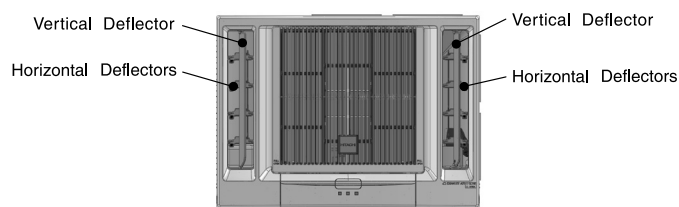

HORIZONTAL DEFLECTORS

Horizontal deflectors at both sides of the outlets can be set to direct discharge air upward, downward or forward direction.

CAUTIONS

To avoid dew forming on the deflectors which eventually may drip to the floor, please do not adjust horizontal deflectors extremely downward position or vertical deflectors extremely leftward or rightward position during cool operation for a long time. Also, do not adjust the vertical deflectors position by hand or any other object.

AIR EXHAUST LEVER

Set the air exhaust lever to the down (↓) OPEN position for air ventilation in the room. The air exhaust lever should normally be kept in up (↑) CLOSE position during cooling operation and in the case of typhoon.

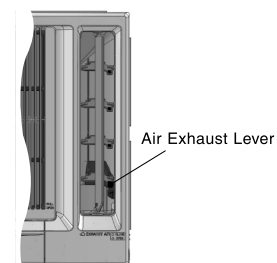

WASABI AIR PURIFYING FILTER

Always stop the operation before installing the wasabi air purifying filter.

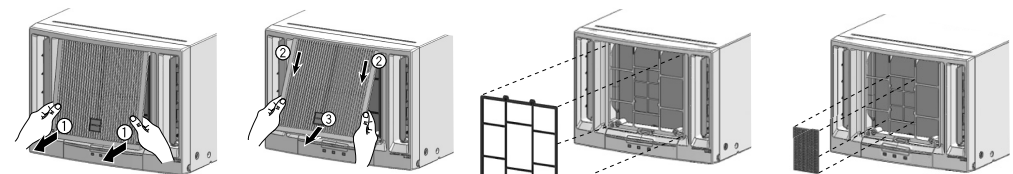

- Pull and remove the suction grille
- Remove the pre-filter
- Install the wasabi air purifying filter in the frame
- Install back the pre-filter and close the suction grille

Wasabi air purifying filter are not washable. It is recommended to use vacuum to clean it. It can be used use for 1 year time. Type number for this wasabi air purifying filter is <SPX-CFH9W>. Please use this number for ordering when you want to renew it.

NOTES ON OPERATION

TEMPERATURE AND HUMIDITY

Avoid to use the room air conditioner for cooling operation when the outside temperature is below 21°C (70°F). Recommended operation humidity should be below 80%. Continuous operation at over 80% humidity (indoor) will cause some dews form on the outlet grille and deflectors of the unit.

NOISE

In a quiet environment during the starting or stopping the operation, phenomena like flowing sound of refrigerant in the refrigerating cycle and rubbing noise from the fan casing may occasionally occur, but this is normal for the operation. Water will be condensed on the evaporator coil and collected in the bottom tray, it is picked up by the condenser fan and blown onto the condenser coil, this creates a "splashing" sound which is normal.

ODOR

The odor will possibly be emitted from the room air conditioner especially at the starting of operation and in a high humidity condition. This is not abnormal phenomena because of the various kind of odors emitted by smoke, food stuffs, cosmetics and others which may stick to the room air conditioner. So, the pre-filter and the evaporator regularly must be cleaned to reduce the odor.

THE IDEAL WAYS OF OPERATION

<p>Suitable Room Temperature</p> <p>Warning Freezing temperature is bad for health and a waste of electric power.</p>	<p>Install curtain or blinds</p> <p>It is possible to reduce heat entering the room through windows.</p>	<p>Ventilation</p> <p>Caution Do not close the room for a long period of time. Occasionally open the door and windows to allow the entrance of fresh air.</p>
<p>Do Not Forget To Clean The Pre-Filter</p> <p>Dusty pre-filter will reduce the air volume and the cooling efficiency. To prevent from wasting electric energy, please clean the pre-filter every 20 days.</p>	<p>Please Adjust Suitable Temperature For Baby And Children</p> <p>Please pay attention to the room temperature and air flow direction when operating the unit for baby, children and old people who have difficulty in movement.</p>	

FOR USER'S INFORMATION

The Air Conditioner And The Heat Source In The Room

Caution
If the amount of heat in the room is above the cooling capability of the air conditioner (for example: more people entering the room, using heating equipments and etc.), the preset room temperature cannot be achieved.

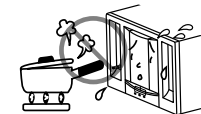

When Lightning Occurs

Warning
To protect the unit during lightning, please stop operating the unit and remove the plug from the socket.

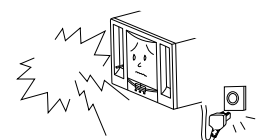

MAINTENANCE

CAUTION

Always turn off and unplug the unit before any cleaning or maintenance to ensure safety

PRE-FILTER

If the pre-filter is clogged with dust, the air flow volume will be decreased and resulting in poor cooling performance, and increased operating noise. Be sure to clean the filter about every 20 days.

- Remove the suction grille by pulling the bottom corner and slightly lift up the suction grille.
- Pull downward to unhook the suction grille and remove the suction grille.
 - Lift and unhook the bottom of the pre-filter and remove it.
 - Remove dust from the pre-filter by using a vacuum cleaner. If the pre-filter is very dirty, wash it with detergent and rinse properly with water. Dry the pre-filter with soft cloth and do not expose it to heat or under direct sunlight.
 - Install the pre-filter by fitting the top hooks and then hook the bottom of the pre-filter.
 - Attach the suction grille back to its place by hooking at the top side to the front cover, then gently push at bottom corner.

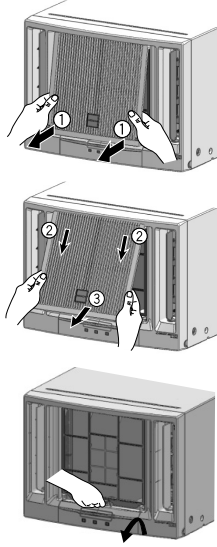

CAUTION

- Do not use hot water above 40°C for cleaning the pre-filter.
- Do not operate the air conditioner without the pre-filter.

FRONT COVER AND SUCTION GRILLE

Clean the front cover and suction grille with a soft dry cloth. When it is excessively dirty, wipe it with a soft cloth dampened with mild soap, then wipe it again thoroughly with a soft dry cloth.

The suction grille can also be removed and be washed with water and mild soap. Remove the suction grille in the following manner.

- Remove the suction grille by pulling the bottom corner and slightly lift up the suction grille.
- Pull downward to unhook the suction grille and remove the suction grille.

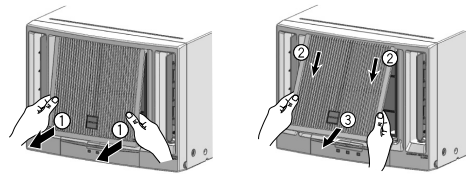

CAUTIONS

Never use hot water above 50°C, erosive chemicals or brush to clean the front cover and suction grille because they will damage the plastic surface.

BEFORE ASKING FOR SERVICE

Check the following items before asking for service. If the malfunction persists, please contact service centre.

Symptom	Check
Does not operate at all	<ol style="list-style-type: none"> Is the power cord loosened or unplugged? Is the fuse blown out or the circuit breaker tripped? Is the voltage normal? Is the main switch set to "OFF" position?
Poor cooling performance	<ol style="list-style-type: none"> Is the pre-filter covered with heavy dust? Clean pre-filter and replace it. Is the temperature setting correctly? Is the sunlight fall directly in the air conditioner? Leave a space of 900 mm (3 feet) behind the rear side of air conditioner. Is the air flow on the rear side (outdoor) blocked? Leave a space of 900 mm (3 feet) behind the rear side of air conditioner. The doors or windows may be opened widely or there are other sources of heat in the room. Is the ventilation damper opened?

CAUTION

If the power supply cord is damaged, it must be replaced by the manufacturer, its service agent or similiarly qualified persons in order to avoid a hazard.

INSTALLATION INSTRUCTIONS

Remove all the shipping parts before installation and consult an authorised dealer concerning installation requirements, otherwise may damage the air conditioner.

LOCATION

- Select a location that can support the weight of the air conditioner and will not cause increased operating noise and vibration.
- Select a location to avoid direct sunlight on the air conditioner.
- Select a good location for efficient air circulation.
- Select a location where there is no obstacles near the air inlet and outlet.

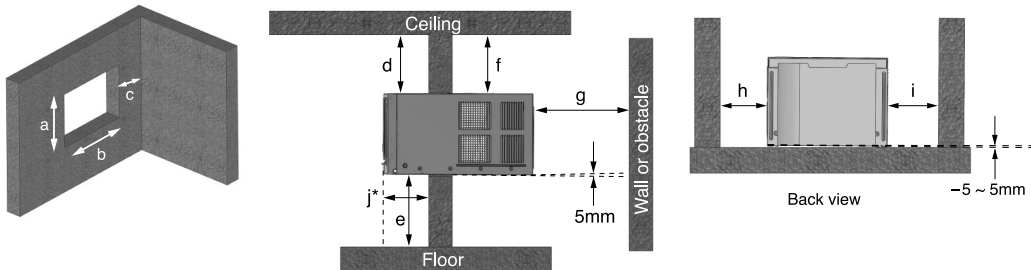

Model	Dimension (mm)									
	a	b	c	d	e	f	g	h	i	j*
RA-08QDF	365	490	Over 200	Over 100	Over 1200	Over 150	Over 900	Over 200	Over 200	170 or more
RA-10QDF										
RA-13QDF	395	580	Over 200							170 or more

* Recommended dimension for performance testing purpose only.

CAUTIONS

- The installation material must be corrosion proof, especially the air conditioner is installed near the sea or hot spring.
- Do not install air conditioner in the places where there is a possibility of inflammable gas leaks.
- Secure tightly the cabinet with screws to the frame. Otherwise there may be danger of the air conditioner dropping.
- Please keep the recommended installation dimensions. Otherwise waterdrops or malfunction may occur.

<IA0000: A>

POWER SOURCE

- Check the capacity of wiring and power outlet. The power outlet should be used exclusively for the air conditioner. Do not use it with other appliances. Any wiring must follow the national wiring regulation.
- Ground the air conditioner to prevent danger of electric shock.
- Connect the air conditioner with power source securely.
- Use a fuse as below:

RA-08QDF RA-10QDF RA-13QDF	15A Circuit Breaker	Voltage rating Operatable Voltage range	50Hz 220V 50Hz 198-242V	CAUTION This appliance must be earth
----------------------------------	------------------------	---	----------------------------	--

REMOVE THE FRONT COVER

Remove the front cover in the following manner.

- Remove the suction grille by pulling the bottom corner and slightly lift up the suction grille.
- Pull downward to unhook the suction grille and remove the suction grille.
 - Lift and unhook the bottom of the pre-filter and remove it.
 - Remove two screws which secure the front cover.
 - Remove the front cover from lower side. Disconnect the timing motor connector at right side of the electrical box.

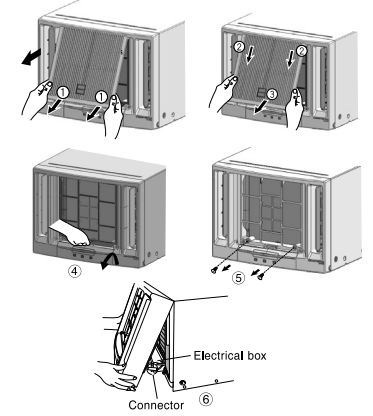

SLIDE OUT OF UNIT

- Remove the four screws which fasten the base pan to the cabinet at the side and back.
- Remove the stopper at front left side of base. (RA-13QDF)
- Slide out the unit by pulling the handles.

After slide in the unit, please install a sealer between the base pan and cabinet to prevent from entering rain water in case of typhoon. Reinstall the stopper at front side of base and fasten the unit to cabinet at the side with the screw, then refit the front cover.

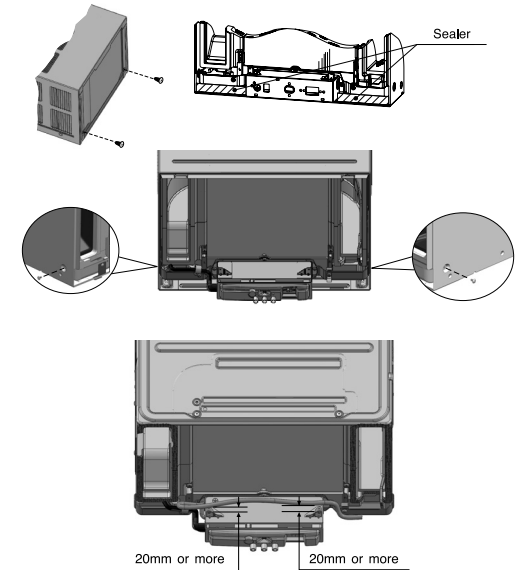

POWER CORD ARRANGEMENT

If power cord is withdrawn from left side of unit, please arrange the power cord as in figure after installing the front cover.

DRAIN PAN

CONDENSED WATER DRAINAGE

This air conditioner use a "turbo fan splashing ring" which is designed to splash the condensated water on the condenser surface for maximum cooling efficiency, thus producing a splashing sound. If you are uncomfortable with the sound, you can install an outside drainage by using the following procedure which may, reduce the cooling operation performance.

- Remove the rubber plug from the base pan.
- Install the drain pan by using 2 pieces of screws (provided) at the cabinet.
- Connect the drain pan with the drain hose to drain point. (Drain hose or tubing can be purchase locally. Drain hose inner diameter should be around ø13mm or 1/2 inch.)
- Pour 2 glasses of water into the drain pan to ensure the drainage is functioning normal.
- Slide the air conditioner unit back into the cabinet.

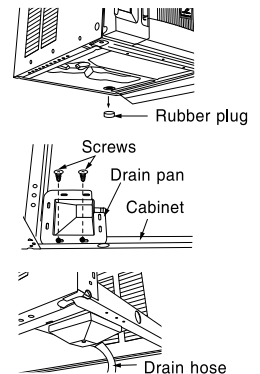

The Drain Pan can be used in any positions as below and be secured by 2 screws to avoid water dropping problem:

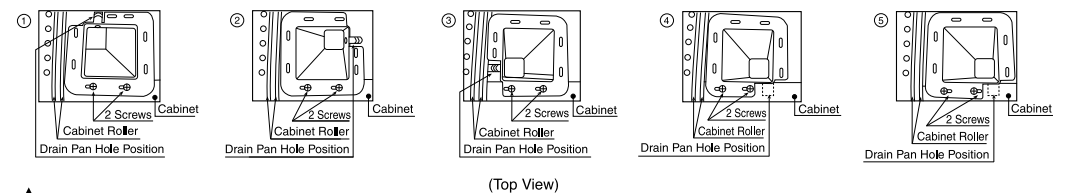

CAUTIONS

Drain Pan edge shall not exceed the cabinet roller.

CAUTION

When using operation of auto swing function, if the vertical deflector swing angle is incomplete, please turn the deflector manually to the utmost left angle. An abnormal sound will occur when adjusting the vertical deflector. This sound indicates that the engagement of gear is in position and does not affect the operation.

When raining, rain water will enter the outdoor side. An abnormal sound will occur during operation of unit in raining conditions and approximately 10 minutes after rain stop. This will not affect the performance or liability of the room air conditioner.

INSTALLATION WORK INSPECTION CHECK LIST

Item No.	Check Item	Confirm
1	Have you removed the shipping parts? Please check the caution sheet which is attached at front cover.	
2	Is the incline of room air conditioner regarding front and rear, right and left all right after installation?	
3	Is the strength of installation sufficient?	
4	Have you grounded the room air conditioner?	
5	Have you fastened the unit to the cabinet?	
6	Have you done a test operation, and are there any abnormal phenomena?	

Recommended temperature range for safety testing should be as below:

Cold side	Dry bulb	21 - 32°C
	Wet bulb	15 - 23°C
Hot side	Dry bulb	21 - 43°C
	Wet bulb	15 - 26°C

MEMO

.....

.....

.....

NAMES AND FUNCTIONS OF REMOTE CONTROLLER

REMOTE CONTROLLER

This controls the operation of the air conditioner. Signal range to reach air conditioner is about 7 meters. If inverter lamp is used, the range of control may be shorter. It can be fixed on a wall using the fixture provided. Before fixing it, make sure the air conditioner can be controlled from the remote controller.

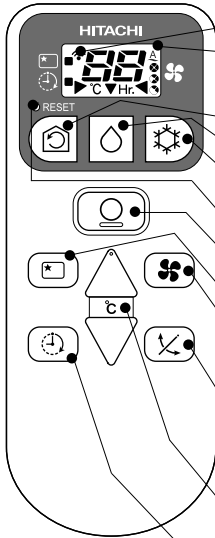

- **Transmission sign**
The transmission sign blinks when a signal is sent.
- **Display**
This indicates the room temperature setting, timer status, operation mode and fan speed setting.
- **CIRCULATION button**
Press this button to set air circulation in the room or start the operation.
- **DEHUMIDIFYING button**
Press this button to dehumidify the room or start the operation.
- **COOLING button**
Press this button to set cooling mode in the room or start the operation.
- **RESET button**
- **STOP button**
Press this button to stop the operation.
- **SLEEP TIMER button**
Press this button to set the sleep timer.
- **FAN SPEED button**
Press this button to change the fan speed. Every time you press this button, the intensity of circulation will change from (AUTO) to (HI) to (MED) to (LOW).
- **AUTO SWING button**
Press this button to set auto swing or stop angle of the vertical air deflector.
- **TEMPERATURE button**
Press this button to raise or lower the temperature setting. (Keep pressed, and the value will change more quickly.)
- **ON-TIMER button** Press this button to setting the turn on time.

	CIRCULATION / START
	DEHUMIDIFYING / START
	COOLING / START
	FAN SPEED
	AUTO
	HI
	MED
	LOW
	SLEEP TIMER
	STOP
	ON TIMER
	AUTO SWING

Precautions

- Do not put the remote controller in the following places.
 - In direct sunlight.
 - Near a heat source.
- Handle the remote controller carefully. Do not drop it on the floor, and away from water.
- Once the air conditioner stops, it will not restart for about 3 minutes (unless you turn the power switch off and on or unplug the power cord and plug it in again).
This is to protect the device and does not indicate a failure.

COOLING OPERATION

Use the device for cooling when the outdoor temperature is 21 ~ 43°C.

If indoor humidity is very high (over 80%), some dew may form on the air outlet grille and deflectors of the unit.

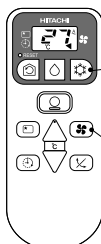

1

Press the (COOLING) button so that the display indicates pointing to button. Cooling operation starts with a beep. The cooling function does not start if the temperature setting is higher than the current room temperature. The cooling function will start as soon as you set the temperature below the current room temperature.

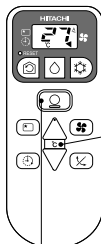

2

Set the desired FAN SPEED with the (FAN SPEED) button (the display indicates the setting).

(AUTO) : The FAN SPEED is HI at first and change to MED or LOW automatically when the preset temperature has been reached.

(HI) : High fan speed.

(MED) : Medium fan speed.

(LOW) : Low fan speed.

3

Set the desired room temperature with the TEMPERATURE button (the display indicates the setting).



The range of 25 ~ 28°C is recommended as the room temperature for cooling.

The temperature setting and the actual room temperature may vary depending on conditions.

STOP Press the (STOP) button to stop operation.

■ As the settings are stored in memory in the remote controller, you only have to press the (COOLING) button next time.

DEHUMIDIFYING OPERATION

Use the device for dehumidifying when the room temperature is over 16°C.

When it is under 15°C, the dehumidifying function will not work.

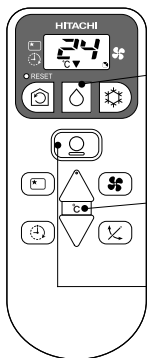

1

Press the (DEHUMIDIFY) button so that the display indicates pointing to button.

Dehumidifying operation starts with a beep. The FAN SPEED is set at LOW automatically. The FAN SPEED button does not work.

2

Set the desired room temperature with the TEMPERATURE button (the display indicates the setting).



The range of 20-26°C is recommended as the room temperature for dehumidifying.

STOP

Press the (STOP) button to stop operation.

■ As the settings are stored in memory in the remote controller, you only have to press the (DEHUMIDIFYING) button next time.

■ Dehumidifying Function

When the room temperature is higher than the temperature setting: The device will start to dehumidify and lower the room temperature to the preset level.

When the room temperature is lower than the temperature setting: Dehumidifying will be performed at the temperature setting slightly lower than the current room temperature, regardless of the temperature setting. The function will stop (the fan will stop emitting air) as soon as the room temperature becomes lower than the setting temperature. You might feel a bit colder in dehumidifying operation.

CIRCULATION OPERATION

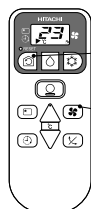

1 Press the (CIRCULATION) button so that the display indicates pointing to button. Circulating operation starts with a beep.



2 Press the FAN SPEED button and select the desired FAN SPEED (the display indicates your choice).

3 Press the temperature control button to set to the desired temperature.

STOP Press the (STOP) button to stop operation.

■ As the settings are stored in memory in the remote controller, you only have to press the (CIRCULATION) button next time.

■ Circulation Function

- During circulation operation, compressor will not run and there is no cooling operation with only fan running.
- When the setting temperature is higher than room temperature, fan will stop running.

HOW TO SET THE SLEEP TIMER

Press the (SLEEP TIMER) button, and the display changes as shown below.

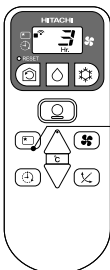

Mode	Indication
SLEEP TIMER	

SLEEP TIMER: The device will continue working for the designated number of hours and then turn off.
 Point the signal window of the remote controller toward the indoor unit, and press the SLEEP TIMER button.
 The timer information will be displayed on the remote controller. The TIMER lamp lights with a beep from the indoor unit.

NOTE

- After sleep timer time is up and when press sleep timer button again, the timer will be set as last setting.
- Sleep timer effective only once.

Explanation of the sleep timer

The device will control the FAN SPEED and room temperature automatically so as to be quiet and good for people's health.

You can set the sleep timer to turn off after 1 to 12 hours. The FAN SPEED and room temperature will be controlled as shown below.

Operation with the sleep timer

Function	Operation
Cooling and dehumidifying 	The room temperature will be controlled 2°C above the setting temperature and the FAN SPEED will be set to LOW setting 1 hour after the setting of the sleep timer.

HOW TO SET THE ON TIMER

Press the  (ON TIMER) button, and the display changes as shown below.

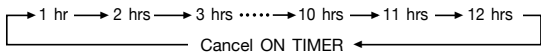
Mode	Indication
ON TIMER	

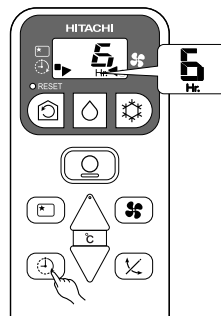

■ Operation will start for setting temperature at setting time (The starting time may differ depend on the room temperature and set temperature).

HOW TO REPLACE THE BATTERIES IN THE REMOTE CONTROLLER

When using the remote controller, if there is no response from the air conditioner or the remote controller display is dim, please try to replace the batteries.

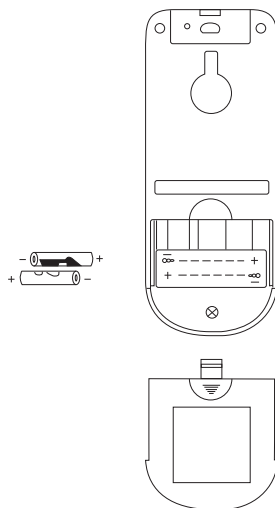

1 Remove the cover as shown in the figure and take out the old batteries.

2 Install the new batteries.
The terminal of the batteries should match the marks in the case.

CAUTION

1. Do not use new and old batteries, or different kinds of batteries together.
2. Take out the batteries when you do not use the remote controller for 2 months or longer.
3. Use high quality and high performance AAA batteries to avoid short operating life and electrolyte leakages